

SCALA2

The Grundfos SCALA2 is a fully integrated water booster pump delivering perfect water pressure in all taps at all times - even with multiple taps and showers running at the same time. It packs a pump, motor, tank, sensor, drive and non-return valve into one compact unit. With its intelligent pump control, SCALA2 automatically adjusts performance to both inlet pressure and water consumption in the home. SCALA2 has a sound level of 47 dB (A) in typical use and thereby offers one of the lowest noise levels of any booster in the market.



FEATURES

Perfect water pressure - in all taps at all times

SCALA2 has an intelligent pump control that always ensures constant pressure by detecting any variation in water and inlet pressure.

It immediately adjusts its operation to deliver the required discharge pressure. SCALA2 will maintain sufficient water pressure

Low noise

SCALA2 has a water cooled, high-efficiency permanent magnet motor that ensures a low noise operation at 47 db(A) in typical use. SCALA2 is as quiet as a modern dishwasher and one of the most quiet boosters in its class

Compact

SCALA2 is a fully integrated solution with pump, tank, sensor, drive and non-return valve in one unit that will fit in any existing installation and in compact spaces like a kitchen cupboard. It weighs only 10 kg and is easy to handle

Robust and reliable

SCALA2 offers a long lifetime. It can even be installed outside. It's made of quality materials and has protective measures like dry-run protection and anti-cycling

Easy installation and self-priming

SCALA2 is an all-in-one solution designed for fast and easy installation. Simply connect the pipes, prime the pump and connect to the power. It has a large priming hole, which makes it easy to prime

Energy efficient

SCALA2 features a high efficient permanent magnet motor using only 550 W (Power input max (P1)) and has a power consumption of only 270 W in daily use (3 bar/12 l/min)



OPERATING CONDITIONS

Max. ambient temperature	55 °C (131 °F)
Max. liquid temperature	45 °C (113 °F)
Max. system pressure	10 bar (145 PSI, 1 MPa)
Max. inlet pressure	6 bar (87 PSI, 0.6 MPa)
Max. head	45 m (147 feet)
Pumped liquid	Clean, fresh water and chlorinated water < 300 ppm

PERFORMANCE CURVE

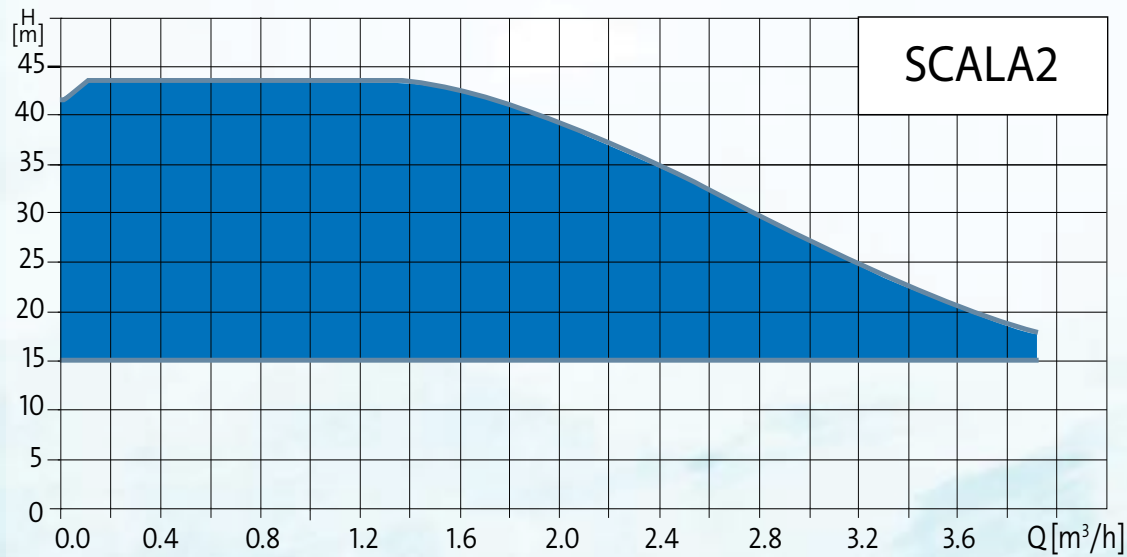

DIMENSIONS PICS

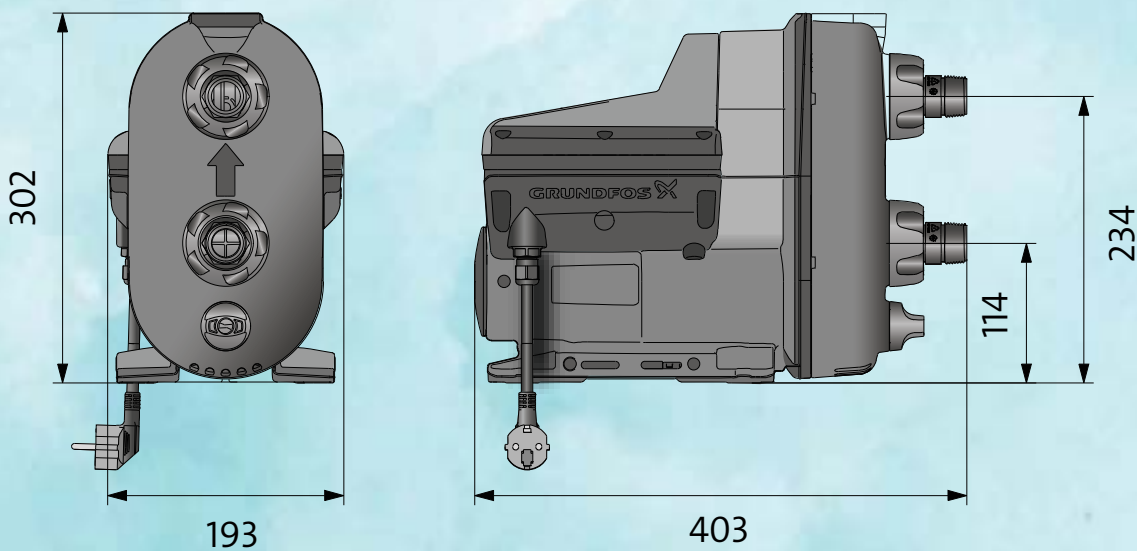

All dimensions in mm

PRODUCT RANGE

Part Code	Model	Power		Weight [kg]
		kw	Hp	
98562862	SCALA2 3-45	0.55	0.7	10